

# A2X Series 2.5 x 2.0 mm SMD Automotive Crystal Resonator

A : Automotive

2 : 2.5×2.0×0.55 mm | SMD2520-4P

X : Crystal Resonator

## Feature

- AT-cut Crystal Construction
- Ultra miniature Ceramic surface mount with Metal Lid
- High temperature, high precision and reliability Characteristics
- Pb-free and RoHS/Green compliant.
- AEC-Q200 Qualified

## Applications

- Industrial Control & Automation
- ADAS
- LiDAR (Light Detection and Ranging)
- Power Control & Conversion

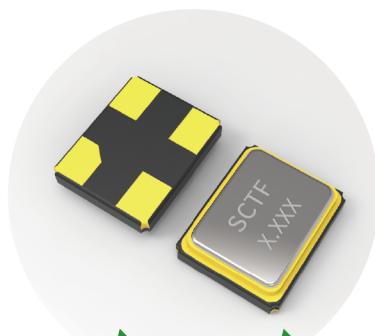

## Electrical Specifications

Item	Symb.	Min.	Typ.	Max.	Unit	Notes
Frequency Range	Freq.	12.000		54.000	MHz	
Oscillation Mode		Fundamental (AT-cut)				
Frequency Tolerance	$\Delta f/f$			$\pm 10$	ppm	at 25°C $\pm 2^\circ\text{C}$
Operating Temperature	T_use	-40		85	°C	
		-40		105	°C	
		-40		125	°C	
Storage Temperature Range	T_sta	-55		125	°C	
Shunt Capacitance	C0			3	pF	
Drive Level	DL		10	100	$\mu\text{W}$	
Load Capacitance	CL	6		20	pF	
Insulation Resistance	IR			500	M $\Omega$	at DC 100V
Aging	f_age			3	ppm	1st. Year at 25°C

## Frequency Stability & Operating Temperature Range

Temp. \ FT	$\pm 15\text{ppm}$	$\pm 20\text{ppm}$	$\pm 30\text{ppm}$	$\pm 50\text{ppm}$
-40°C to +85°C	$\Delta$	★	★	★
-40°C to +105°C		$\Delta$	★	★
-40°C to +125°C			$\Delta$	★

★: Available     $\Delta$ : Conditional

## Equivalent Series Resistance

Frequency Range	ESR(Max.)
12MHz $\leq$ Freq. < 16MHz	200 $\Omega$
16MHz $\leq$ Freq. < 20MHz	80 $\Omega$
20MHz $\leq$ Freq. < 30MHz	60 $\Omega$
30MHz $\leq$ Freq. < 35MHz	50 $\Omega$
35MHz $\leq$ Freq. $\leq$ 54MHz	40 $\Omega$

# A2X Series 2.5 x 2.0 mm SMD Automotive Crystal Resonator

A : Automotive

2 : 2.5×2.0×0.55 mm | SMD2520-4P

X : Crystal Resonator

## Dimensions (UNIT:mm)

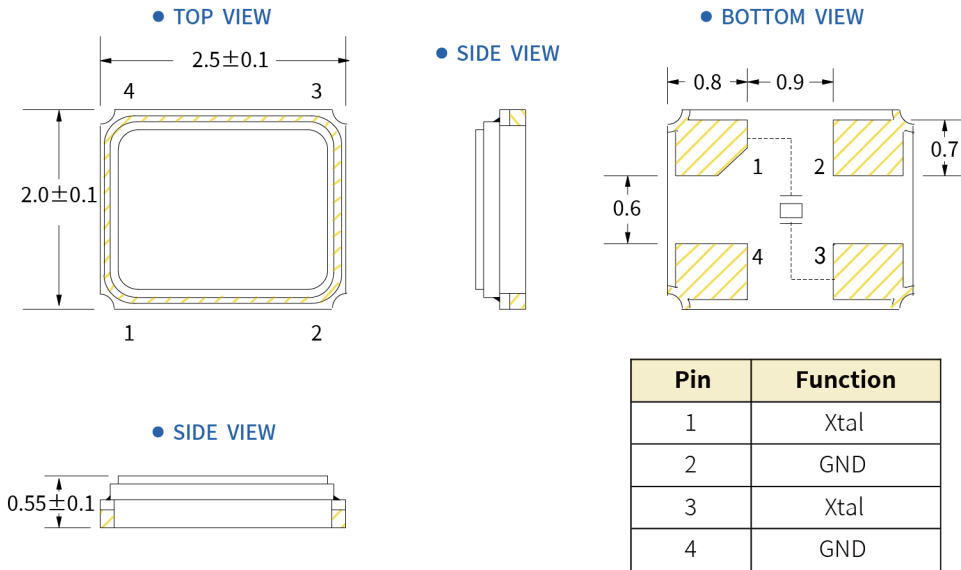

## Solder pad layout (UNIT:mm)

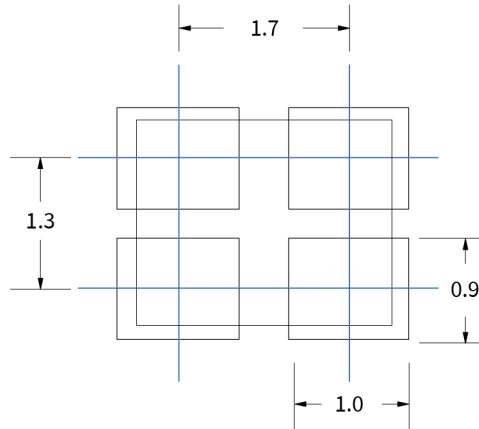

## Options and Part Identification : Example SXA2B12.000F1010G30

Company	Ratings	Ceramic Package	Frequency Code [MHz]	Vibration Mode	Load Capacitance	Frequency Tolerance	Operating Temperature	Frequency Drift
<b>SX</b>	<b>A</b>	<b>2B</b>	<b>X.XXX</b>	<b>F</b>	<b>10</b>	<b>10</b>	<b>G</b>	<b>30</b>
Code Company	Code Ratings	Code Ceramic Package	Frequency	Code Vibration Mode	Code Load Capacitance	Code Frequency Tolerance	Code Operating Temperature	Code Frequency Drift
SX SCTF	A AEC-Q100, AEC-Q200	0B 1.6 x 1.2 x 0.35mm [4PAD] 1B 2.0 x 1.6 x 0.45mm [4PAD] 2B 2.5 x 2.0 x 0.55mm [4PAD] 3B 3.2 x 2.5 x 0.7mm [4PAD] 5B 5.0 x 3.2 x 0.8mm [4PAD] 5A 5.0 x 3.2 x 0.8mm [2PAD]	12.000	F AT - Fundamental	S Please specify CL in pF or S for series 06 6pF 08 8pF 10 10pF 12 12pF 20 20pF	10 ±10ppm 20 ±20ppm	F -40°C ~ +85°C G -40°C ~ +105°C M -40°C ~ +125°C	15 ±15ppm 20 ±20ppm 30 ±30ppm 50 ±50ppm

If you have other parameter requirements, you can contact **SCTF** at any time.

# A2X Series 2.5 x 2.0 mm SMD Automotive Crystal Resonator

A : Automotive

2 : 2.5×2.0×0.55 mm | SMD2520-4P

X : Crystal Resonator

## Frequency Temperature Characteristics

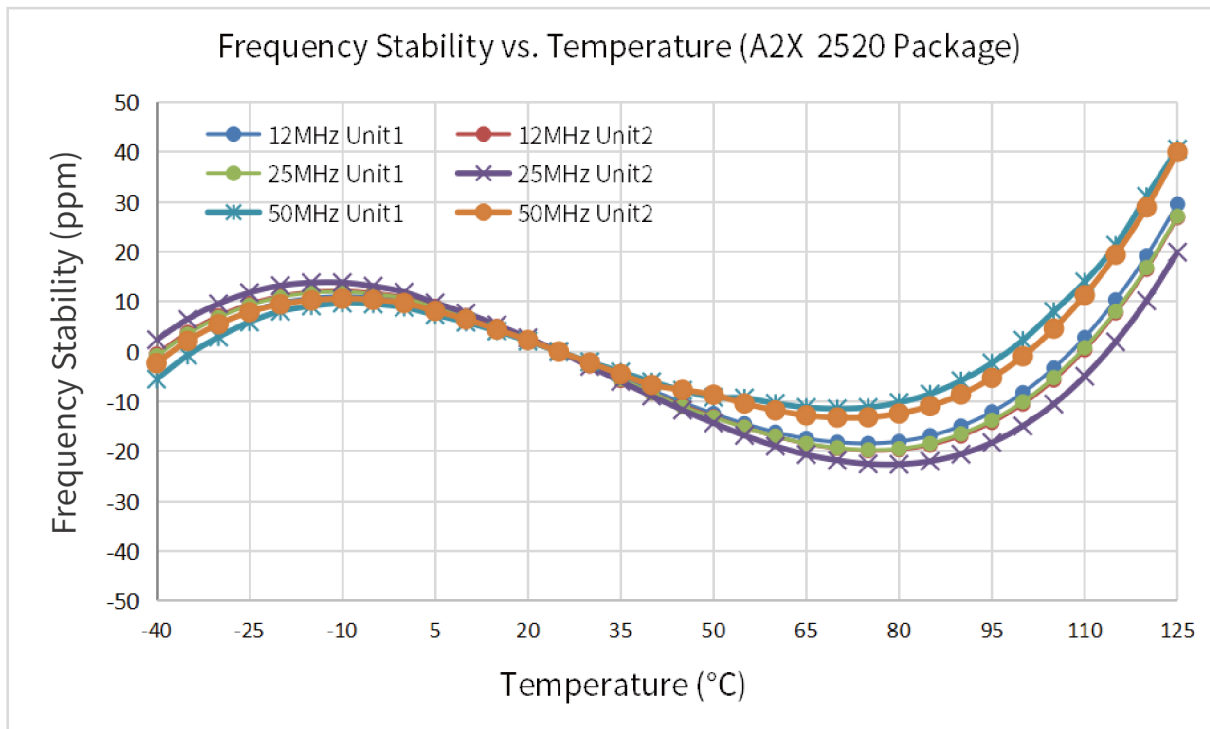

## Product Structure & Marking Information

### Product Structure

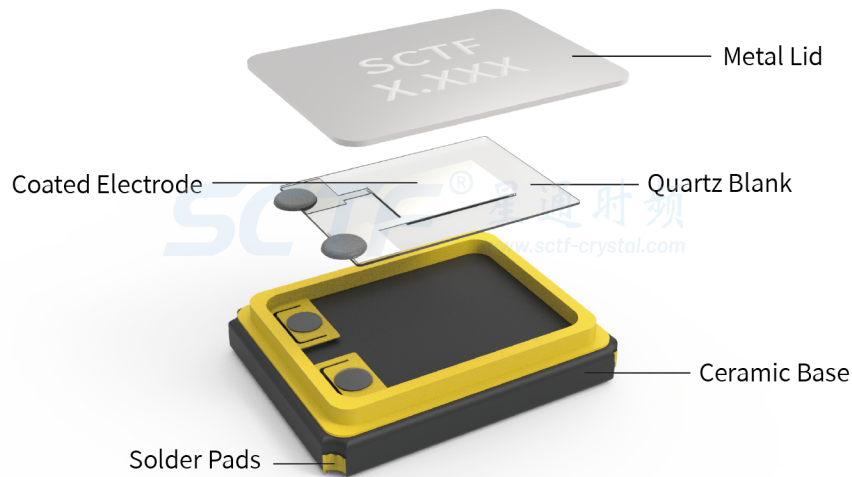

### Marking Information

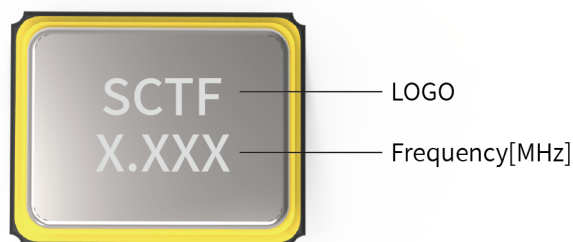

# A2X Series 2.5 x 2.0 mm SMD Automotive Crystal Resonator

A : Automotive

2 : 2.5×2.0×0.55 mm | SMD2520-4P

X : Crystal Resonator

## Suggested Reflow Profile

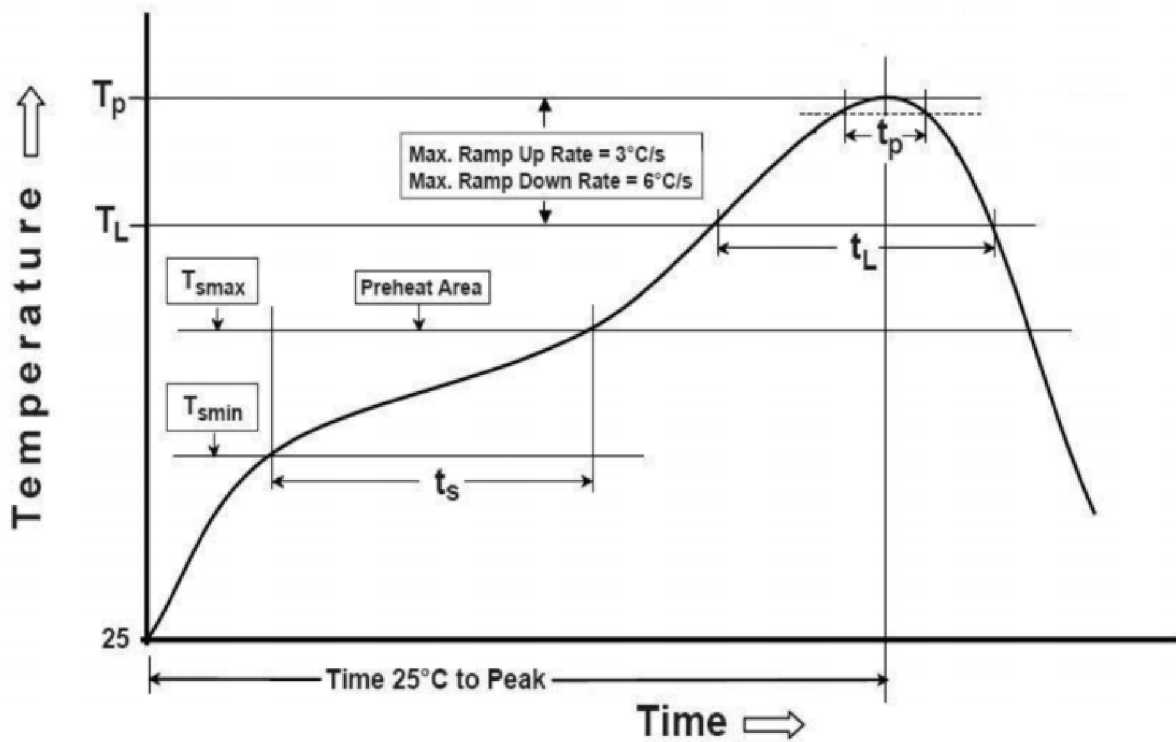

Profile Feature	Sn - Pb Eutectic Assembly	Preheat / Soak
Preheat / Soak <ul style="list-style-type: none"> <li>● Temperature Min ( Ts min )</li> <li>● Temperature Max ( Ts max )</li> <li>● Time ( Ts min to Ts max )</li> </ul>	100°C 150°C 60-120 seconds	150°C 200°C 60-120 seconds
Ramp - up rate ( TL to Tp )	3°C/ second max.	3°C/ second max.
Time maintained above <ul style="list-style-type: none"> <li>● Liquidous temperature ( TL )</li> <li>● Time ( tL ) maintained above TL</li> </ul>	183°C 60-150 seconds	217°C 60-150 seconds
Peak package body temperature ( Tp )	235°C	260°C
Time within 5° C of the specified classification temperature ( Tp )	20 seconds	30 seconds
Ramp - down rate ( Tp to TL )	6°C/ second max.	6°C/ second max.
Time 25° C to peak temperature	6 minutes max.	8 minutes max.
<b>Suggest reflow times</b>	<b>2 Times max.</b>	

# A2X Series 2.5 x 2.0 mm SMD Automotive Crystal Resonator

A : Automotive

2 : 2.5×2.0×0.55 mm | SMD2520-4P

X : Crystal Resonator

## Packaging Information

T=Tape and reel (3,000pcs/reel)

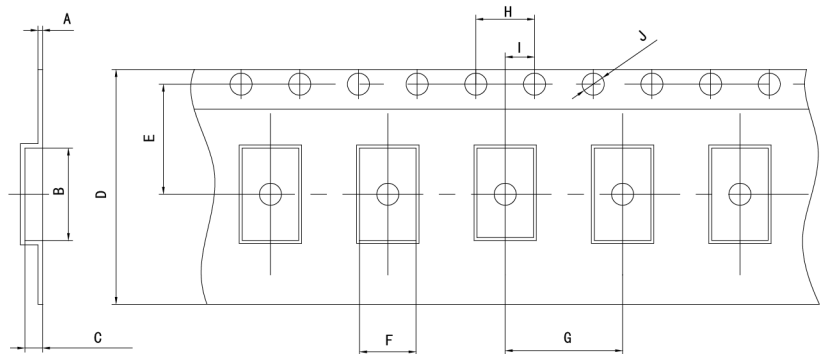
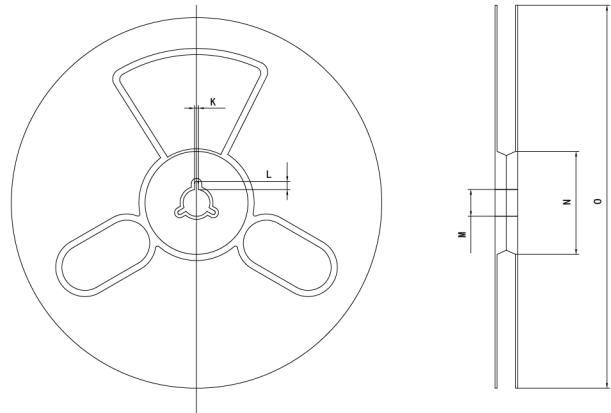

### Pocket Tape Dimensions(mm)

Series	A	B	C	D	E	F	G	H	I	J	K	L	M	N	O
A2X	0.25±0.05	2.25±0.1	0.8±0.1	8.0±0.1	3.5±0.1	2.25±0.1	4.0±0.1	4.0±0.1	2.0±0.1	φ1.5±0.1	2.0±0.2	4.0±1.0	φ13±0.5	φ60±1	φ180±1

## Common Frequencies – MHz

A2X Series				
12.000	12.288	14.31818	16.000	16.384
18.432	19.200	20.000	22.1184	22.5792
24.000	24.305	24.576	25.000	26.000
27.000	27.120	28.63636	30.000	32.000
37.400	38.400	40.000	48.000	50.000
52.000	54.000			